

OX-AN[®] Landfill Gas Monitoring System Operation Manual

Issue 3.2

Raymond Coupland Environmental

**Unit W1
Technology Court
Whinbank Park
Newton Aycliffe
County Durham
DL5 6DA
United Kingdom
Tel: (44) 0800 7720894**

www.ox-an.com

Contents

1.0 GENERAL OPERATION.....	3
1.1 ALARM LEVEL 1 - AMBER	3
1.2 ALARM LEVEL 2 - RED	3
1.3 ISOLATION OF CHANNELS	4
1.4 ISOLATION OF SENSORS	4
1.5 ALARM HOLD OFF TIME	4
1.6 VISUAL INDICATORS	5
1.6.1 Beacons.....	5
1.6.2 LEDs.....	5
2.0 ACCESSING USER AND ENGINEER FUNCTIONS.....	6
2.1 USER DISPLAY AND KEYS.....	6
2.2 USER FUNCTIONS.....	7
2.2.1 Change Display Mode - ENTER key.....	7
2.2.2 Increment Channel – EDIT Key	7
2.2.3 Fast Cycle – UP Key.....	7
2.2.4 Normal Cycle – DOWN Key	7
2.2.5 VAC Test / Print Pending – VAC / PRINT Key.....	7
2.2.6 Channel Lock – CYCLE Key.....	7
2.2.7 Reset – RESET Key.....	8
2.2.8 Mute – MUTE Key.....	8
2.3 EVENTS.....	8
2.3.1 Printing Events	8
2.4 ENGINEER FUNCTIONS	9
2.4.1 Editing Numeric Values.....	11
2.4.2 Yes/No Inputs.....	11
2.4.3 Changing Channel.....	11
2.5 MENU OPTIONS.....	12
2.5.1 Print Setup.....	12
2.5.2 Clear Events	12
2.5.3 Isolate Channel.....	12
2.5.4 Isolate O2	13
2.5.5 Isolate CH4.....	13
2.5.6 Isolate CO2.....	13
2.5.7 Set Time	14
2.5.8 Set Date	14
2.5.9 CO ₂ Alarm Red	14
2.5.10 CO ₂ Alarm Amb	15
2.5.11 CH ₄ Alarm Red	15
2.5.12 CH ₄ Alarm Amb	15
2.5.13 O ₂ Alarm Red.....	16
2.5.14 O ₂ Alarm Amb.....	16
2.5.15 Hold Off (sec)	16
2.5.16 Mute Time (min)	17
2.5.17 Active Channels	17
2.5.18 O2 Active	17
2.5.19 CH4 Active.....	17
2.5.20 CO2 Active.....	18
2.5.21 Printer.....	18
2.5.22 Exit.....	18
3.0 TEST MODE.....	18
4.0 FAULT CONDITIONS	19
5.0 4-20MA LOOP CALIBRATION	20

5.1 CALIBRATION PROCEDURE	20
5.1.1 <i>Blank EEPROM</i>	20
5.1.2 <i>Pre-Programmed EEPROM</i>	20
5.2 VERIFYING CALIBRATION	22
5.3 SENSOR CALIBRATION	22
6.0 REPLACING PRINTER PAPER	ERROR! BOOKMARK NOT DEFINED.

OX-AN Landfill Gas Monitor

1.0 General Operation

The OX-AN Landfill Gas Safety Monitoring System continuously monitors the level of Carbon Dioxide (CO₂), Methane (CH₄) and Oxygen (O₂) from up to 16 individual locations. Two configurable detection levels provide audible, visual and control outputs. Each location is monitored for approximately 3 minutes.

In a typical application, the first level alarm (amber) is set to a value which is not hazardous to health, but is a warning of a potential problem. The control output (first level relay) from the first level alarm is typically used for initiating any remedial action which may be required to maintain the correct gas levels. This alarm level is non-latching.

The second level alarm (red) is typically set to CO₂, CH₄ or O₂ concentrations which are still not immediately hazardous to health but indicate that immediate action must be taken to rectify the cause of the of increased or decreased gas levels. This action typically involves the removal of personnel.

1.1 Alarm Level 1 - Amber

The system provides independent configurable alarm levels for CO₂, CH₄ and O₂. If the level of either gas rises above its corresponding first alarm level, the amber beacon is illuminated and the amber relay output is activated. The audible alarm is not activated.

If the levels of CO₂ or CH₄ remain above the first alarm levels, or the level of O₂ remains below the first alarm level, the amber beacon and first level relay output will remain activated. If the level of both gasses subsequently falls below their corresponding first alarm levels, the system automatically deactivates the amber beacon and the amber relay output.

The channel LED display shows the relevant channel number. This number remains illuminated until the channel deactivates on the next cycle or another channel activates the amber alarm.

If the current channel is not in Amber alarm the LED display will show the last or highest channel number currently in Amber alarm.

1.2 Alarm Level 2 - Red

If the level of CO₂ or CH₄ rises above the corresponding second (red) configurable alarm level for a period exceeding the hold off time (factory set to 5 seconds), the red beacon is illuminated and the second level relay output is activated. A red alarm

state is also generated for levels of O₂ which remain below the second (red) configurable alarm level for a period which exceeds the hold off time.

Red level alarms also activate the audible alarm (sounder). The sounder can be muted using the mute button or the external mute input.

Note that the red alarm is latching and hence further variations in either gas level will not affect the status of the main alarm relays. Red alarm status can only be removed by pressing RESET.

Note: Whilst in RED alarm state the system continues to monitor other channels and will detect up to a further 16 RED alarm events from other channels.

1.3 Isolation of Channels

Individual channels can be set not to trigger alarms by using the Isolate Channels option from within the Engineer Menu. This feature allows specific input channels to be isolated whilst continuing operation.

1.4 Isolation of Sensors

Individual sensors (CO₂, CH₄ or O₂) can be set not to trigger alarms by using the Isolate O₂, Isolate CH₄ or Isolate CO₂ options from within the Engineer Menu. This feature allows specific gas sensors to be isolated whilst continuing operation.

1.5 Alarm hold off Time

The Hold Off time facility allows false alarms to be reduced by continuing to sample for a specified time after the gas level has risen above the red alarm level to ensure that the level of gas remains above this specified level. For O₂ depletion sensing the gas level must remain below the threshold value.

This facility must be used with caution since long hold off times may cause potentially hazardous situations to occur without alarm. The Hold Off time is factory set to 5 seconds.

1.6 Visual Indicators

1.6.1 Beacons

Green Beacon	CO ₂ or CH ₄ level below alarm levels / O ₂ level above alarm level
Amber Beacon	CO ₂ or CH ₄ level above Amber alarm level / O ₂ level below Amber alarm level
Red Beacon	CO ₂ or CH ₄ level above Red alarm level / O ₂ level below Red alarm level

1.6.2 LEDs

Fault	System fault has occurred
Isolated Sensor/Channel	One or more sensors or channels are isolated
Sounder Muted	Sounder is muted
Fast Cycle	System is in Fast Cycle mode
Print Pending	An event is ready to print
System Healthy	System is powered

2.0 Accessing User and Engineer Functions

Opening the enclosure outer door provides access to both the User and Engineer functions. User functionality is provided via the keys and does not use a menu-based system. Pressing the Engineer Switch located below the LCD provides access to the Engineer functions. Engineer functionality is controlled using a scrollable menu.

Note that the inner door need not be opened to access any functionality. Mains wiring is accessible behind the inner door and hence only suitably qualified persons should have access to this area whilst the system is powered.

Note that the Fault output will be energised whilst the system is in Engineers Mode.

2.1 User Display and Keys

The User key functionality is shown below.

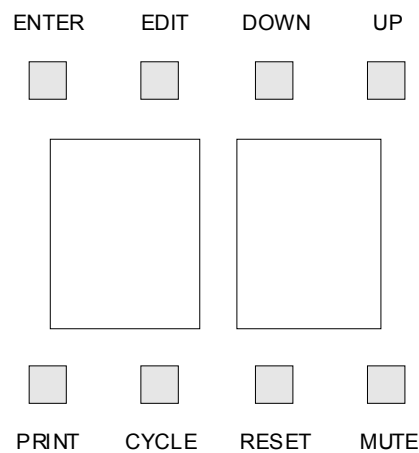

In normal operation (User mode) the display will show:

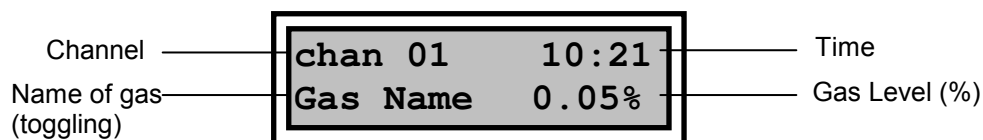

The system will move through each channel showing the relevant gas levels. Note that the fields will show –NS- if no sensor is fitted or the sensor fails. This level will cause a Red alarm.

2.2 User Functions

2.2.1 Change Display Mode - ENTER key

Pressing the ENTER key toggles the screen output to show the amber and red alarm levels for each gas. The screen continues to toggle between the alarm level screens and the default screens until the ENTER is pressed once more.

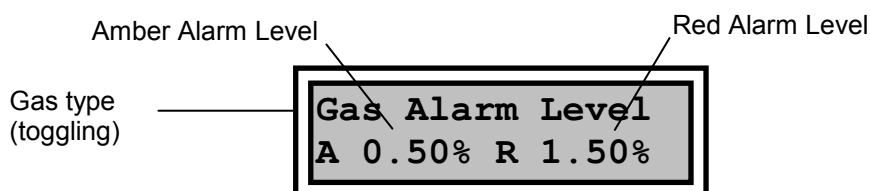

2.2.2 Increment Channel – EDIT Key

The EDIT key moves the sampling to the next active channel. The button is not active during a channel change or alarm hold off period.

2.2.3 Fast Cycle – UP Key

The UP key moves the sampling rate to fast cycle mode. The Fast Cycle LED is illuminated.

2.2.4 Normal Cycle – DOWN Key

The DOWN key moves the sampling rate to normal cycle mode.

2.2.5 VAC Test / Print Pending – VAC / PRINT Key

If the Print Pending LED is illuminated, press the VAC / PRINT key to print the pending event.

If there are no pending events to print, pressing the VAC / PRINT Key initiates a vacuum test.

Note: Following a vacuum test the display will indicate the outcome of the test for a number of seconds. This delay avoids sudden changes in pressure which can result in false alarm activations.

2.2.6 Channel Lock – CYCLE Key

Pressing the CYCLE key toggles between locking on a single channel and cycling between channels. The CYCLE key locks the system onto the channel currently being scanned. In this mode the locked channel number will be intermittently displayed on the LEDs.

Note the system remains in the channel lock state until the CYCLE Key is pressed again or the system is reset.

2.2.7 Reset – RESET Key

Pressing the RESET key resets the system by removing audible and visual alarm indications. The red and amber level alarm relays are deactivated by a system reset and will only be reactivated if the system identifies an alarm condition following the reset.

Note: channel locking is removed following a reset.

2.2.8 Mute – MUTE Key

Pressing the MUTE key during a second level (red) alarm will mute the audible sounder. After a configurable time period the sounder will be reactivated.

The visual indication and control outputs are not affected by the use of the mute facility.

Pressing the MUTE Key whilst the system is in normal operation activates the Test Mode – see section 3.0.

2.3 Events

Whenever a red alarm state occurs, the system records details of the event in EEPROM. The event will be displayed on the LCD during red alarm state and will be removed when the system is reset.

For each event the LCD will display:

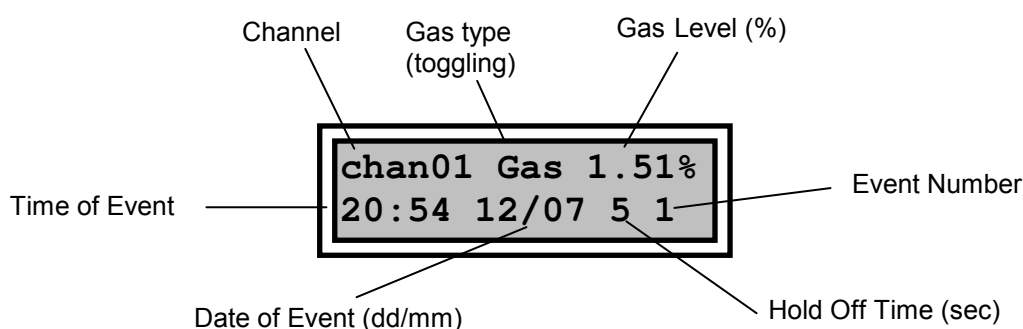

2.3.1 Printing Events

If a printer is fitted and activated, the Print Pending LED will flash to indicate that an event is due for printing. To print events press the PRINT button. Note that up to 16 events may be pending but events are printed individually, i.e. the PRINT button must be pressed for each event.

2.4 Engineer Functions

The Engineer switch is located below the LCD on the display board.

Pressing the Engineer switch moves the panel into “Engineer mode”. This mode is used for configuration and provides access to the Engineer Menu.

Care should be taken when using the Engineer Menu since no input verification or storage confirmation is provided. In Engineer Mode the keys are reassigned as:

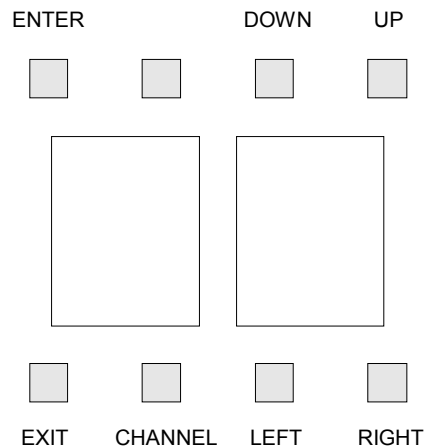

On entering Engineer Mode the LCD will show:



From this position, the Engineer Menu can be accessed with the UP and DOWN keys. The Engineer Menu comprises:

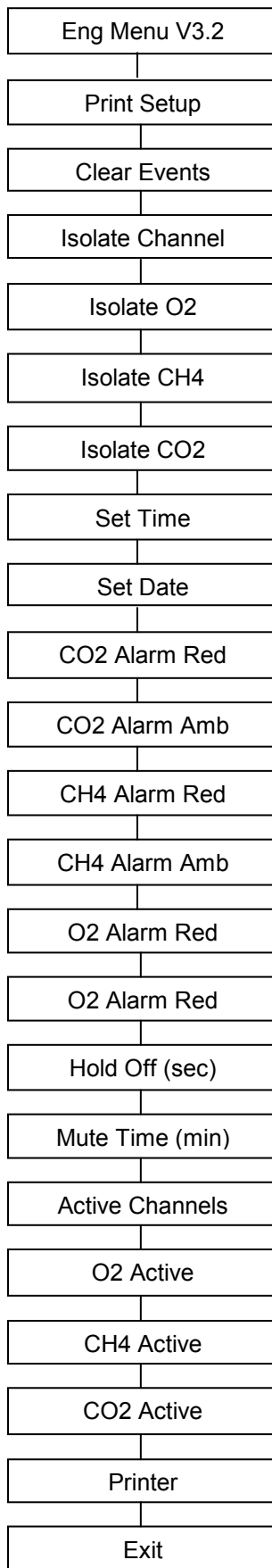

2.4.1 Editing Numeric Values

To edit numeric values press the ENTER key when the relevant menu option is displayed.

The data is immediately presented for editing. Individual digits are incremented or decremented using the UP and DOWN keys. Use the LEFT and RIGHT Keys to move between digits.

Save the edited data by pressing the ENTER key. Exit without saving by using the EXIT key.

2.4.2 Yes/No Inputs

To edit Yes/No values press the ENTER key when the relevant menu option is displayed. The input value is then available for editing.

For Yes/No entry the entered value toggles with either the UP or DOWN key. Save the edited data by pressing the ENTER key or exit without saving using the EXIT key.

2.4.3 Changing Channel

For options which are channels specific, the channel can be incremented using the CHANNEL key after selecting the parameter to edit (from the menu).

Note that the channel must be selected prior to editing the data. If the channel is incremented without explicitly saving an edited value, any changes will be lost.

In practise this means that the editing sequence is:

1. Select menu option
2. Select channel
3. Edit data
4. Save data

This sequence must be repeated for each channel.

The channel is shown in the lower left of the screen.

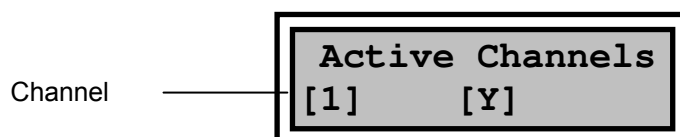

2.5 Menu Options

The following sections provide details of the individual menu options.

2.5.1 Print Setup

Requires optional printer.

Yes/No input for printing the setup data held in the system memory.

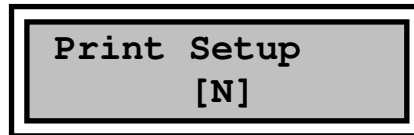

2.5.2 Clear Events

Requires optional printer.

Yes/No input for clearing any pending prints (indicated by flashing print pending LED)

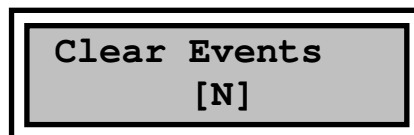

2.5.3 Isolate Channel

This option provides facilities for determining whether the input from a channel should be allowed to trigger alarm states. Isolated channels are not scanned.

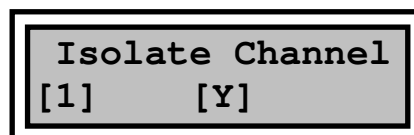

- Value Y or N
- Channel specific

The Isolated Sensor/Channel LED is illuminated if one or more channels are isolated.

2.5.4 Isolate O2

This option provides facilities for determining whether the value from the O₂ sensor should be allowed to trigger alarm states.

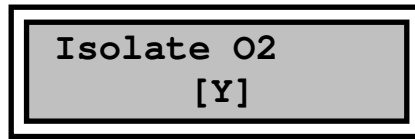

- Value Y or N

The Isolated Sensor LED is illuminated if one or more sensors are isolated.

2.5.5 Isolate CH4

This option provides facilities for determining whether the value from the CH₄ sensor should be allowed to trigger alarm states.

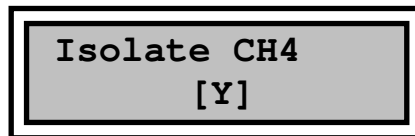

- Value Y or N

The Isolated Sensor LED is illuminated if one or more sensors are isolated.

2.5.6 Isolate CO2

This option provides facilities for determining whether the value from the CO₂ sensor should be allowed to trigger alarm states.

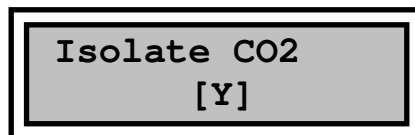

- Value Y or N

The Isolated Sensor LED is illuminated if one or more sensors are isolated.

2.5.7 Set Time

This option allows the real time clock to be set. The input format is 24 hour.

Set Time Alarm Set Red

- No input data validation is carried out
- Single value for all channels

2.5.8 Set Date

This option allows the real time clock date to be set.

Set Date 00/00/00

- No input data validation is carried out
- Single value for all channels

2.5.9 CO₂ Alarm Red

This CO₂ value determines the level for the activation of the red alarm relays, the sounder and the red alarm level beacons.

CO₂ Alarm Red 1.00%
--

- Min Value = 00.0%
- Max value = 9.99%
- Single value for all channels

2.5.10 CO₂ Alarm Amb

This CO₂ value determines the level for the activation of the amber alarm relays and the amber beacons.

CO2 Alarm Amb 0.50%

- Min Value = 00.0%
- Max value = 9.99%
- Single value for all channels

2.5.11 CH₄ Alarm Red

This CH₄ value determines the level for the activation of the red alarm relays, the sounder and the red alarm level beacons.

CH4 Alarm Red 1.00%

- Min Value = 00.0%
- Max value = 9.99%
- Single value for all channels

2.5.12 CH₄ Alarm Amb

This CH₄ value determines the level for the activation of the amber alarm relays and the amber beacons.

CH4 Alarm Amb 0.50%

- Min Value = 00.0%
- Max value = 9.99%
- Single value for all channels

2.5.13 O₂ Alarm Red

This O₂ value determines the level for the activation of the red alarm relays, the sounder and the red alarm level beacons.

O2 Alarm Red 19.5%

- Min Value = 00.0%
- Max value = 99.9%
- Single value for all channels

2.5.14 O₂ Alarm Amb

This O₂ value determines the level for the activation of the amber alarm relays and the amber beacons.

O2 Alarm Amb 20.5%

- Min Value = 0.0%
- Max value = 99.9%
- Single value for all channels

2.5.15 Hold Off (sec)

This value determines the time, in seconds, for which the level of CO₂ or CH₄ must remain above the red alarm or the level of O₂ remain below the red alarm level before the red alarm state is activated. This facility helps to reduce the incidence of alarms caused by fast changing O₂, CO₂ or CH₄ levels.

Hold Off (sec) 005

- Min Value = 0
- Max value = 255
- Single value for all channels

2.5.16 Mute Time (min)

This value determines the time, in minutes, for which the sounder is muted following either a MUTE key press or an external mute. The sounder will be reactivated after the time has elapsed.

Mute Time (min) 005

- Min Value = 0
- Max value = 255
- Single value for all channels

2.5.17 Active Channels

This option provides facilities for determining whether the input from a channel should be allowed to trigger alarm states. Inactive channels are not scanned.

Active Channels [1] [Y]

- Value Y or N
- Channel specific

2.5.18 O2 Active

This option provides facilities for determining whether the value from the O₂ sensor should be allowed to trigger alarm states. Inactive channels are not scanned.

O2 Active [Y]

- Value Y or N

2.5.19 CH4 Active

This option provides facilities for determining whether the value from the CH₄ sensor should be allowed to trigger alarm states. Inactive channels are not scanned.

CH4 Active [Y]

- Value Y or N

2.5.20 CO2 Active

This option provides facilities for determining whether the value from the CO₂ sensor should be allowed to trigger alarm states. Inactive channels are not scanned.

```
CO2 Active
[Y]
```

- Value Y or N

2.5.21 Printer

Requires optional printer.

Yes/No input for activating/deactivating the optional printer. When this option is set, the Print Pending LED will be illuminated whenever an event occurs.

```
Printer
[Y]
```

2.5.22 Exit

Pressing the ENTER key when this option is displayed exits the Engineer mode and returns the system to User mode.

```
Exit
```

3.0 Test Mode

Test Mode allows the system to be tested without activation of the alarm output relays.

To enter Test Mode, press the Mute key or the external Mute input whilst the system is in normal operation.

In Test mode the system flashes the Fault LED. The LCD will show the current channel, gas levels and a warning message to indicate the change of mode.

```
chan 01    TEST!!
Gas Name   0.05%
```

If a red alarm does not occur within 3 minutes the system will automatically return to normal mode. A Reset also returns the system to normal mode.

4.0 Fault Conditions

The integrity of the data stored within the system memory is crucial to the correct operation of the alarm system. The OX-AN Landfill Gas Monitor uses an integer checksum for verification of the contents of the serial memory and the on-chip EEPROM data. If a checksum failure occurs, the FAULT LED will be illuminated and an amber alarm state will be activated. The LCD will display a warning message.

In the event of a checksum error you must contact your Service Engineer immediately.

5.0 4-20mA Loop Calibration

The unit is calibrated for loop current measurements of up to 20mA by applying a load of 3mA as the zero level and a load of 23mA as the full-scale level. These calibration values are stored within the EEPROM (IC9).

Calibration involves drawing a known steady current from the loop circuitry using a suitable calibration unit.

Note that the calibration menu is displayed when the CAL terminals adjacent to the processor are shorted. These terminals must remain shorted throughout the full calibration procedure.

5.1 Calibration Procedure

5.1.1 Blank EEPROM

If the EEPROM is blank the board should be powered up with the CAL jumper in place.

The following is displayed:

A rectangular box with a double border, containing the text "Write Defaults?". The box has a light gray background and is centered on the page.

Press ENTER to write default values to the serial memory.

Remove Cal jumper and reset board. Follow instructions for calibration using pre-programmed EEPROM.

5.1.2 Pre-Programmed EEPROM

Power-up the board with CAL jumper removed.

Fit CAL jumper.

The following is displayed:

A rectangular box with a double border, containing the text "Write Defaults?". The box has a light gray background and is centered on the page.

If required press ENTER to write default values to the serial memory.

Warning all edited Engineer data will be lost if you write default settings to the serial memory

Press EXIT (PRINT button) leave the existing data within the serial memory.

The display will now show:

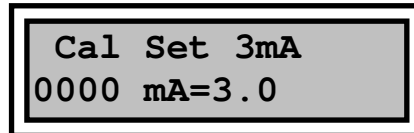

Cal Set 3mA
0000 mA=3.0

Note: the lower line is used for verifying calibration and should be ignored on un-calibrated boards.

1. Set the current being drawn by the calibration module to 3mA (read from the meter NOT the LCD display).
2. Press ENTER to calibration the zero level. Press EXIT (PRINT button) to leave without calibrating.

The following is displayed:

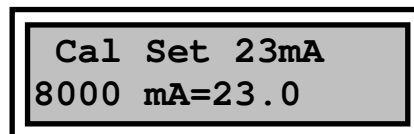

Cal Set 23mA
8000 mA=23.0

Note: the lower line is used for verifying calibration and should be ignored on un-calibrated boards.

3. Set the current being drawn by the calibration module to 23mA (read from the meter NOT the LCD display).
4. Press ENTER to calibration the full scale level. Press EXIT (PRINT button) to leave without calibrating.
5. Remove power from the board.
6. Remove the CAL jumper
7. Remove the calibration module.

The board is now calibrated for loop current measurements.

5.2 Verifying Calibration

To verify that a board is calibrated enter the calibration menu by attaching a jumper to the CAL pins.

Press EXIT (PRINT button) leave the existing data within the serial memory.

A calibrated board will show the correct mA reading for current which is drawn from the loop.

Press EXIT (PRINT button) to exit both calibration steps without saving.

5.3 Sensor Calibration

Individual gas sensors should be calibrated using calibrated gases.

6.0 Loading Printer Paper

6.0.1 Paper Setting

NOTE

- Be sure to use paper rolls that meet the specifications.
- Do not use paper rolls that have the paper glued to the core because the printer cannot detect the paper end correctly.
- Take care not to get your fingers caught in the printer when installing or replacing the paper roll.

6.0.2 Paper Loading

- Make sure that the printer is not receiving data; otherwise, data may be lost.
- Open the printer door by applying your finger on both sides of the lower printer door and pull forward and downwards. – figure 1
- Follow the same procedure for the upper door.
- With both upper and lower doors open the paper roll tub is accessible. Remove the empty paper roll spindle by pulling the spindle towards you. In some instances opening up one or both of the side spring clips may be needed to enhance spindle removal. - figure 2
- Insert the new paper roll. Be sure to note the correct direction that the paper comes off the roll as shown. – figure 3
- Pull out a small amount of paper and then close the upper door first, followed by the lower door. The printer should auto feed approx. 2” (50mm) of paper, this should ensure correct alignment and confirms that paper is feeding smoothly. The front panel LED should turn green and the printer is now ready to receive more print data.

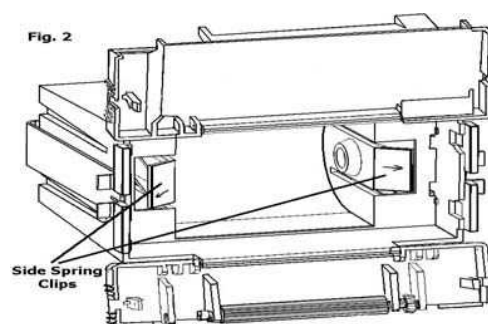
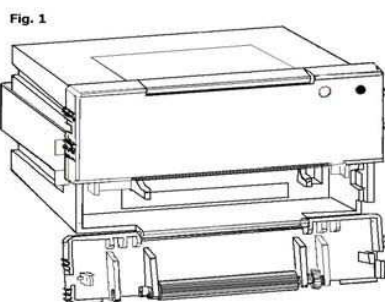

Fig. 3

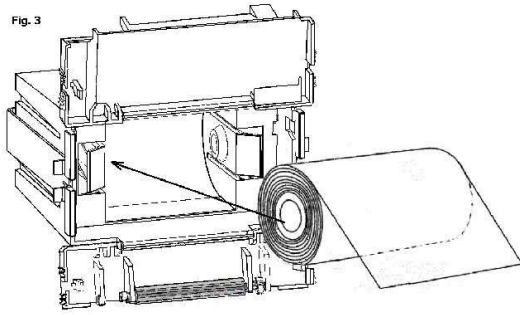
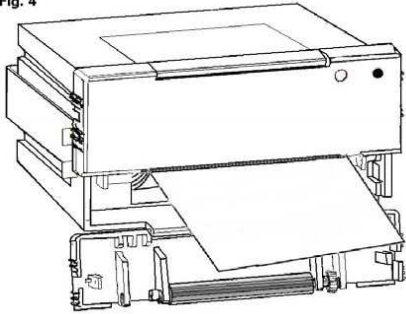

Fig. 4



6.0.3 Paper Loading during a print cycle.

If the end of paper roll takes place during printing the printer will detect that no paper is present and will send a busy signal to the host. This will interrupt printing to allow a new paper roll to be fitted.

Follow the paper loading instructions in section 3.4.1. After completing the paper loading procedure and as soon as the printer auto advances the 4" (100mm) described in part f of 3.4.1 the printer will release the busy status line and data will resume being received by the printer, printing will commence automatically.